



**RAJNAGAR TEXTILE MILL
(A UNIT OF NATIONAL TEXTILE CORPORATION LTD)
OPPOSITE UTTAR GUJARAT PATEL NAGAR SOCIETY
BABUPURA HARIPURA ASARWA-380016
Phone No. 079-22165009 / 22165729**

GSTIN: - 24AAACN2847D1ZU

CIN NO.: - U74899DL1968GOI004866

WEBSITE: www.ntcltd.org
E-mail : rnmpurchase@yahoo.com

INVITES

TENDER DOCUMENT FOR
FOUNDATION WORK FOR
FABRIC ROLL LOADING HOIST CRAIN
Inquiry No.:- 90/COMM/ENG/17-18

SALE OF TENDER DOCUMENT	02.09.2017 TO 18.09.2017
DATE OF PRE BID MEETING	10.09.2017 AT 11.30 A.M.
LAST DATE FOR SUBMISSION OF TENDER	18.09.2017 Up to 3.00 P.M.
DATE FOR OPENING OF TENDER (Technical Bid)	18.09.2017 AT 04.00 P.M.

Date:02.09.2017

Tender Notice

**Sub: FOUNDATION WORK FOR FABRIC ROLL LOADING HOIST
CRAN AT RAJNAGAR MILLS, AHMEDABAD**

RAJNAGAR MILLS, AHMEDABAD is inviting Sealed Tenders from the approved and eligible contractors of CPWD/State PWDs/Railways and other Contractors of repute, well established in line and experienced in the execution of similar magnitude, who fulfill the terms and conditions of this tender of the following work at **RAJNAGAR MILLS AHMEDABAD.**

1. ELIGIBILITY CRITERIA FOR PARTICIPATION IN TENDER.

- 1) To be eligible for award of this contract, Tenderers shall satisfy satisfactory evidence to tender committee headed by **GENERAL MANAGER RAJNAGAR MILLS, AHMEDABAD** of their eligibility, their capability and adequacy of resources to carry out the contract effectively.

In this context, all tenders submitted in technical bid (Cover I) shall include the following information with documentary evidence.

- a.) Actual Proof of Annual Turnover: The bidder should have achieved a minimum annual financial turnover of Rs. 10 Lacs in each of the last two years. The notarized true copy of the duly CA certified copies of the audited balance sheets as proof of annual turnover shall be enclosed along with the technical bid.
- b.) Work Experience: The tenderer should have satisfactorily completed in his own/ firm name, At least two work of similar nature.
 - a. Similar works means Road repairs, construction of MS Structure etc.
- c.) Bidder should have minimum 2 years' experience of similar works.
- d.) Bidder should submit GST registration certificate along with Tender.
- e.) All other relevant document in company name/ own to submit by Bidder.

Based on eligibility criteria & site visit, tenderer should qualify minimum 75% marks for the project.

- 2) Bidder should have EPF and ESIC registration. Bidder should also submit last 6 months payment along with the tender.
- 3) Bidder with the NSIC / MSME registration certificate will be preferred for the work.
- 4) Exemption from submission of EMD/Tender Fee : Parties as per MSME act, 2006 / NSIC registered parties. The certificate shall be valid on the date of tender opening and must cover the items tendered.
- 5) Bidder requires to submit office proof along with tender. Bidder preferably should have registered/branch office.
- 6) Every tenderer is expected, before quoting his rates, to inspect the site of the proposed work at their own expenses to ascertain availability of space for storage of materials, water, power and other facilities for the works.

Bidding firms who do not meet all the above eligibility criteria (a to e) may be disqualified in Technical Bid & tender shall be rejected summarily.

The original supporting Documents of all above eligibility criteria (a to e) of L-1 bidder may be verified by the Corporation before awarding the contract.

SCOPE OF WORK AND SPECIFICATION

1. SCHEDULE OF COST (Preamble)

- a. For assessing proper quality and type of working involvement the bidder is advised to visit the site at his cost before filling the rates in tenders.
- b. Contractor has to carry out the complete job and provide any items necessary as per actual site condition and good engineering practice and shall form part of scope of supply. The cost of such items is deemed to be included in the rates quoted by bidder in the tender.
- c. The rates quoted for the bill of quantities shall be on the best Principle of Engineering analysis and the arithmetical extension for arriving at the amount shall be accurately carried out.
- d. The rate quoted shall be for each item in the tender for fully completed item of work and shall include all the items necessary complete to the work to the full intent of specification, general trade practice, and to the full performance / working of the system.

- e. Supply of materials, labour, transportation, loading, unloading, storage, watch & ward at site, GST is applicable bidder has to follow the rules as per Government law as applicable, and any other taxes, overhead, profit, any other incidental charges to complete the work and supply Insurance coverage for the period from transit up to end of Commissioning of machine shall be included.

2. **PRE-BID MEETING**

A pre-bid meeting with prospective bidders shall be held at Rajnagar Textile Mill , Ahmedabad on 10.09.2017 at 11.30 AM. The concerned bidders are requested to present them self for any clarification on technical as well as commercial matters regarding to this tender.

Only the prospective bidders are required to submit their suggestions / clarifications during the pre-bid meetings in writing. The suggestions received and found reasonable and acceptable shall be incorporated as corrigendum. Management is not bound to accept any or all suggestions so given in pre-bid meeting. Any suggestions forwarded after the pre-bid meetings shall not be entertained at all by the management.

3. **CORRIGENDUM/AMENDMENTS IN TENDER DOCUMENT**

Amendments if any in tender document shall be uploaded in website www.ntcltd.org , bidders are requested to download the copy of Corrigendum /Amendments from website and attach the same with tender document.

4. **CONTACT DETAILS**

The prospective bidders are requested to contact the following officials for any clarifications / information regarding the tender documents etc.

Name of Official	Contact Number
Shri Subash Pandav Manager(Utility) Rajnagar Textile Mill, Ahmedabad	09824399229
Shri Manish Sahu I/c (Store) Rajnagar Textile Mill, Ahmedabad	07041652647

5. **EARNEST MONEY DEPOSIT**

- a. The prospective bidder who wishes to participate in tenders will have to submit earnest money deposit of Rs. 5000/- by D.D/Pay Order from any Nationalized/ scheduled commercial bank (excluding co-operative / rural bank) notified by RBI.

- b. D.D/Pay Order to be prepared in Name of **"RAJNAGAR TEXTILE MILL AHMEDABAD"** , payable at Ahmedabad.
- c. The tender received without earnest money deposit shall be rejected out rightly.
- d. The earnest money of unsuccessful bidder will be refunded within 15 days after finalization of Contract by at "Par Cheque."
- e. The earnest money of Successful Bidder will be converted into Security Deposit & will be refunded after successful completion of contract.

8. **EMD EXEMPTION**

Concession/Exemption for MSEs Entrepreneurs

For granting the MSEs necessary concession / exemptions as per Govt, directives, bidders are requested to submit the copies of registration certificates issued by the Concerned Authorities. The bidder has to specify whether they are Micro or Small Enterprises and if so, whether they are owned by SC/ST Entrepreneurs

10. **COST OF TENDER DOCUMENTS.**

- a. Interested bidders are requested to obtain the tender documents from Stores Department , Rajnagar Textile Mill by paying Rs. 200/-(non-refundable) being the cost of tender documents by Bank Draft (D.D)/Pay order from any Nationalized/ scheduled commercial Bank notified by RBI (excluding co-operative / rural Bank) on any working day except holiday (Sunday) from 02.09.2017 to 18.09.2016 from 10.00 AM to 5.00 PM.
- b. Bidders may also download the tender document from NTC Ltd., website i.e. www.ntcltd.org . If the Tender Document is downloaded than the cost of tender documents of Rs. 200/- in form of D.D/Pay order drawn from any Nationalized/ scheduled commercial Bank (excluding co-operative / rural Bank) notified by RBI must be submitted along with tender.
- c. Bank Draft/Pay order to be prepared in the Name of **"RAJNAGAR TEXTILE MILL AHMEDABAD"**, payable at Ahmedabad.
- d. Tender shall not be accepted without tender fee in form of DD/Pay Order.

11. **SUBMISSION OF TENDER**

- a. Prospective bidder should submit their complete offer in three separate duly sealed envelope marked A,B,C Complete bid should be submitted I/C (Stores) at **"RAJNAGAR TEXTILE MILL AHMEDABAD"** on or before 18.09.2017 upto 3.00 PM.

- b. Envelope 'A' should be marked **EMD** containing the D.D/Pay Order for EMD and cost of tender document in case of downloaded tender form.
- c. Envelope 'B' should be marked **Technical Bid** containing all documents required to meet qualification criteria and tender document with all the pages signed and stamped by the bidder firm.
- d. Envelope 'C' should be marked **Financial Bid** containing financial bid.
- e. All the three envelopes A, B, C, duly completed should be placed in an outer envelope, which shall be sealed and should contain the following information clearly.
 - i. Tender document No. & Scope of work with due date.
 - ii. Name & address of the bidder on left corner of each envelope A, B, C.
- f. If the envelopes are not sealed and marked as stated above the Rajnagar Textile Mill assumes no responsibility for the misplacement or pre-mature opening of the contents proposal submitted.
- g. Bids submitted by fax telegram, fax, email shall not be entertained and shall be rejected.

12. LATE TENDERS

Tenders received by The **RAJNAGAR TEXTILE MILL AHMEDABAD** after the specified time and due date as per tender documents shall not be eligible for consideration and shall be summarily rejected.

13. REJECTION OF THE TENDER

- a. **RAJNAGAR TEXTILE MILL AHMEDABAD** reserve the right to accept or reject all or any of the tender without assigning any reason whatsoever. It is not obligatory for the Rajnagar Textile mill, Ahmedabad to give any reason for their decisions.
- b. **RAJNAGAR TEXTILE MILL AHMEDABAD** reserve the right not to proceed with the tendering process at any time without notice or liability, and to reject any tender without assigning any reasons. **RAJNAGAR TEXTILE MILL AHMEDABAD** also reserves the right to retender without assigning any reason whatsoever.

14. TENDER OPENING (TECHNICAL BID)

- a. The envelopes A and B containing EMD draft and authorization certificate document shall be opened at Rajnagar Textile mill, Ahmedabad on 18.09.2017 at 04.00 PM before the prospective bidders or their authorized representative who wish to be present

and tender opening committee of Rajnagar Textile mill, Ahmedabad

- b. The price bid envelop "C" shall be kept unopened as it is.
- c. The Financial Bid / Commercial Bid of those bidders who have been found qualified in technical bid as per the document submitted for claiming eligibility criteria shall be communicated by email / fax / telephone for the date and time of financial bid opening.
- d. Management has the right to postpone the opening date of technical bid and financial bid on account of any reason in that case the next date and time of opening of technical bid and financial bid shall be communicated to the qualified bidder's representative by email / fax / telephone.
- e. In the event of tender opening date as stated above falling on holiday the time of tender submission and opening shall be same on the next working days.

15. SITE VISIT

The prospective bidders are requested to visit the Rajnagar Textile Mill , Ahmedabad for collecting all detail about scope of work and other constraints before submission of tender.

16. PRICES

The bidder should quote their prices in prescribed price bid format only clearly and distinctively for all components. The offer quoted in different format shall be liable for rejection.

Income Tax, GST & other Taxes, if any will be deducted as per prevailing rules

17. DELIVERY PERIOD AND COMPLETION OF WORK.

1 months from date of Work Order.

2 SECURITY DEPOSIT:

- a. The earnest money deposit of successful bidder shall be converted into security deposit amount against the work order. This amount will not carry any interest.
- b. The security deposit amount shall be refunded after the successful commissioning of the machinery.

21. PENALTY FOR DELAY IN SUPPLY & COMMISSIONING

0.05% of contract value per week for delay. The delay shall be reckoned from the end of '1' month from the date of work order.

However, in the event of delay in providing clear site or any other genuine reason or delay in project due to the factors beyond control of management penalty clause shall not be applicable.

For claiming waiver in such cases tenderer has to inform to the management with complete details for verification of their claim by Mills nominated officials and consultant.

Based on above verification of claim for waiver of penalty the General Manager of the Mills shall have the power for waiver of penalty.

22. VALIDITY OF OFFER

The offer given by the bidders for the supply shall be valid for 120 days from the date of opening of the tender

23. VALIDITY OF RATE

The rate quoted by the tenderers for the Foundation work shall be valid till the completion of installation and commissioning of the machine.

24. CONTRACT RATES

The contractor shall not be entitled for any increase in the Price of work during the contract period.

25. AWARD OF CONTRACT

The work order will be awarded to successful bidder, whose tender has been determined to be substantially responsive provided further that the bidder is determined to be qualified to perform the contract satisfactorily on comprehensive basis.

In the event of withdrawing the offer by the tenderer at any stage from date of opening of tender the entire EMD deposit along with pending payments of tenderer shall be forfeited.

Any unexcused delay by the tenderer in the performance of its delivery obligations shall render the tenderer liable to any or all of the following sanctions; forfeiture of tenderers EMD deposit and credit amount lying with mills, imposition of liquidated damages, and/or termination of the Contract for default.

If the tenderer fails to deliver work on time or perform the services within the time period(s) specified in the contract, The General Manager of Rajnagar Textile Mill, Ahmedabad shall take such remedial action as may be necessary including termination of contract without prejudice to its other remedies under the Contract.

The General Manager, Rajnagar Textile Mill, Ahmedabad may without prejudice to any other remedy for breach of contract by written notice of default sent to the tenderer terminate the contract in whole or in part:

In the event of termination of the Contract in whole or in part, the Rajnagar Textile Mill, Ahmedabad may procure, upon such terms and in such manner, as it deems appropriate equipment / material / service similar to those undelivered and the tenderer shall be liable to the Rajnagar Textile Mill, Ahmedabad for any excess costs for such similar machinery / equipments / material / service.

26. FORCE MAJURE

The General Manager, Rajnagar Textile Mill, Ahmedabad shall not be liable for any failure or delay in execution of contract due to any cause beyond their control including fire, floods, strikes, go-slow, lock-out, closure, pestilence dissilience dispute with staff dislocation of normal working conditions, war riots epidemics political upheavals Government actions commotion, breakdown of machinery, shortage of labour, demands or otherwise or any other cause or conditions beyond the control of aforesaid causes or not and the existence of such cause or consequence may operate at the sole discretion of The General Manager, Rajnagar Textile Mill, Ahmedabad. To extend the time of execution on the part of The General Manager Rajnagar Textile Mill, Ahmedabad by such period as may be necessary to enable The General Manager Rajnagar Textile Mill, Ahmedabad to affect execution after the cause of delays will have ceased to exist. The provisions aforesaid shall not be limited or abrogated by any other terms of the contract whether printed or written.

28. JURISDICTION

All suits or proceedings relating to any dispute or claim arising out of or in course of performance in this contract shall be filed in appropriate court having jurisdiction in Ahmedabad.

29. ACCEPTANCE.

We have read all the terms and condition of tender documents and we agree to abide by the same. We will supply/Complete all

machinery / equipment's /Material/Work strictly as mentioned in tender document and corrigendum to tender document. We are aware that any additional condition will not be accepted and there will be no change in scope of work.

30. Collecting and stacking of materials

The materials shall be collected and stacked in a systematic manner on either side of the road with a fairly wide margin. The road being divided to approximate divisions longitudinally materials required for each such part length of the road shall be contained and stacked in the length only. Where grading is specified the material shall be stacked in distinct piles for different sizes.

The stacking ground shall be fairly level to facilitate checking the quantity of materials collected and the quantity incorporated in the road subsequently.

- 31.** Where average thickness exceeds the average thickness specified in the item, the extra depth shall be not be paid for unless the same had been carried out under the orders of the Engineer-in-charge. Where however such average thickness is found on measurements to fall short of the average thickness specified in the item the contractor rate will be reduce for the shortfall in thickness.

Signature _____

Name of the Firm _____

Address _____

E-Mail ID _____

Contact No. _____

GST No. _____

ANNEXURE - A
LIST OF APPROVED MAKES

FOR THE ITEMS MISSING IN THE LIST/ THE RELEVANT IS CODE AND SPECIFICATION SHOULD BE BINDING ON THE CONTRACTOR. THE CONTRACTOR SHOULD TAKE APPROVAL WITH THE APPROVED VENDOR LIST PRIOR TO ANY PROCUREMENT FROM THE ENGINEER-IN-CHARGE/PMC

S.NO	ITEMS	APPROVED MAKES
1	CEMENT	ULTRATECH/LAFARGE/AMBUJA/ACC/BIRLA/CENTURY INDIA CEMENT. CEMENT FROM MINI CEMENT PLANTS SHALL NOT BE ALLOWED.
2	RIVER SAND	RIVER SAND CONFIRMED TO IS: 383 SAND SHALL BE RIVER SAND WITH SILT CONTENT LESS THAN 3% BY VOLUME.
3	BRICKS	OLD BRICKS FOR WATER PROOFING. ORDINARY CLAY BRICKS OF ANY BRAND CONFIRMING TO I.S. 1077 MINIMUM CRUSHING STRENGTH 35 KG/SQ CM WATER ABSORPTION ALLOWED 25% FOR BRICKS USED IN paneled WALLS 20% FOR BRICKS USED IN LOAD CARRYING.
4	RUBBLE SOLING	APPROVED HARD VARIETY STONE GRADE FROM 50 MM DOWN TO 15 MM. SIZE AS DEFINE IN RELEVANT IRC OR EQUIVALENT STANDARDS. STONE FOR PREMIX MACADAM- HARD QUALITY SUITABLY GRADE.
5	KERB STONE	HARD BLUE TRAP STONE OR OTHER TYPE. STONES SHALL BE DRESSED ON ALL FACES.
6	MACADAM	SHALIMAR TAR PRODUCTS (STP) OR EQUIVALENT
7	UPVC PIPE	SUPREME / FINOLEX
8	PVC PIPES	PRINCE / SUPREME
9	EPOXY FLOORING	PIDILITE OR EQUIVALENT BRANDS
10	CONCRETE ADDITIVE	SIKA/ STP/ CICO/ FOSROC/ ROFFE/ PIDILITE
11	HUME PIPE	THE BHARUCH CEMENT PIPE WORKS, PRIMA PIPES (CONFIRMING TO IS 458:2003)
12	UPVC RAIN WATER PIPE	SUPREME / FINOLEX
13	WATERPROOFING MATERIALS	SHALIMAR TAR PRODUCTS (STP)/ SIKA/IWL (INDIA) LTD
14	PRECAST CONCRETE TILES/ PAVER BLOCKS	ULTRA / EUROCON/ DURACRETE
15	GI PIPES	JINDAL-HISSAR/ TATA/ ZENITH
16	SWR SOIL/ WASTE & VENT PIPES AND FITTINGS/ TYPE B	SUPREME / FINOLEX

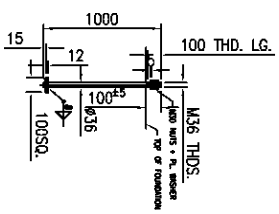
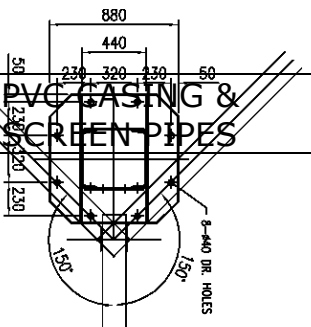
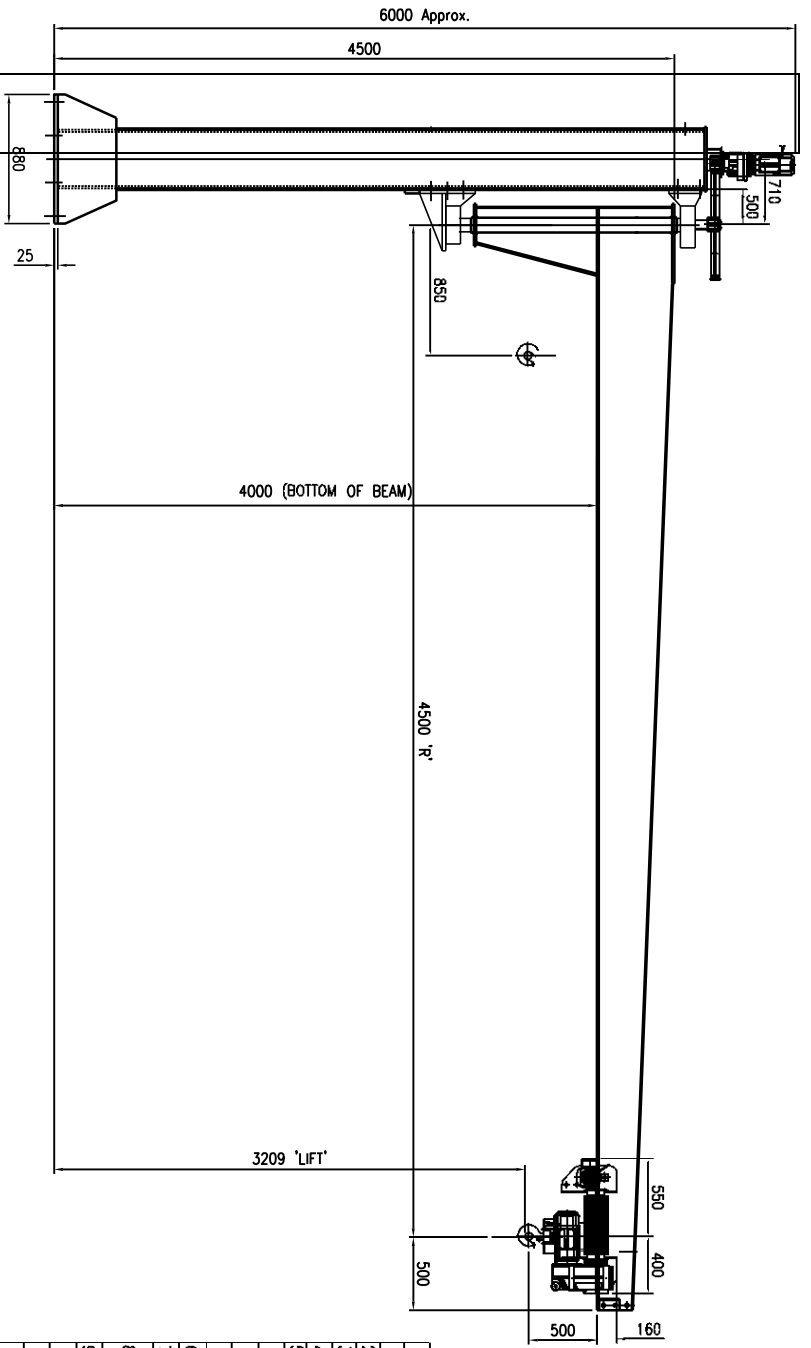

PIN AND NUTS QTY - 8 NOS.
(90% 635 mm, 10% 6-2020)

TECHNICAL SPECIFICATION

1. CAPACITY	2000 kg
2. LIFT	3.5 M
3. CLASS & DUTY	CLASS II MEDIUM DUTY (INDOOR), IS:3938-1983
4. OPERATION	THROUGH PENDENT
5. SPEEDS (M/Min)	
(a) HOIST	3.5 MPM
(b) CT	8 - 10 MPM
(c) SLEW	1 RPM (thru' VFD)
6. SUPPLY VOLTAGE	415V, 3 PHASE, 50 Hz A.C.
7. CONTROL VOLTAGE	110V AC
8. HOIST WEIGHT	500 KGS. (APPROX)
9. MOTOR	
(a) HOIST	2.0 HP, 4POLE, SQ CAGE
(b) CT	0.25 HP x 2 nos, 4 POLE, SQ CAGE
(c) SLEW	0.5HP, 4 POLE, SQ CAGE
10. BRAKES	
(a) HOIST	DCEM Disc type
(b) CT	DCEM Disc type
(c) SLEW	DCEM Disc type
11. WIRE ROPE	8mm DIA, 6x36, 1770 TS, FMC, 4 FALL, IS:2266 MAKE : USHA MARTIN

Client: M/s National Textile Coporation Ltd

ITEM NO.	NO. OFF.	DESCRIPTION	MAT.	UNIT	TOTAL	DRG. NO.
A4				Wt. Kgs.		

THE ELECTROCRANE EQUIPMENT

Shed No. 51 Grant Vishala Estate, S.P. Ring Road, A'Bad
Web: www.electrocrane.com

TOTAL Wt Kgs	-
DRAWN BY	gshank
CHECKED	SGS
APPROVED	SGS
DATE	16/03/17
SCALE	~
GA-2Tx5M-SJC	
Rev : 00	

GENERAL ARRANGEMENT FOR 2Tx5m Arm 300° JIB CRANE

Work Order No. DGM(TECH)/Fabric Roll Loading Hoist/2017/5533

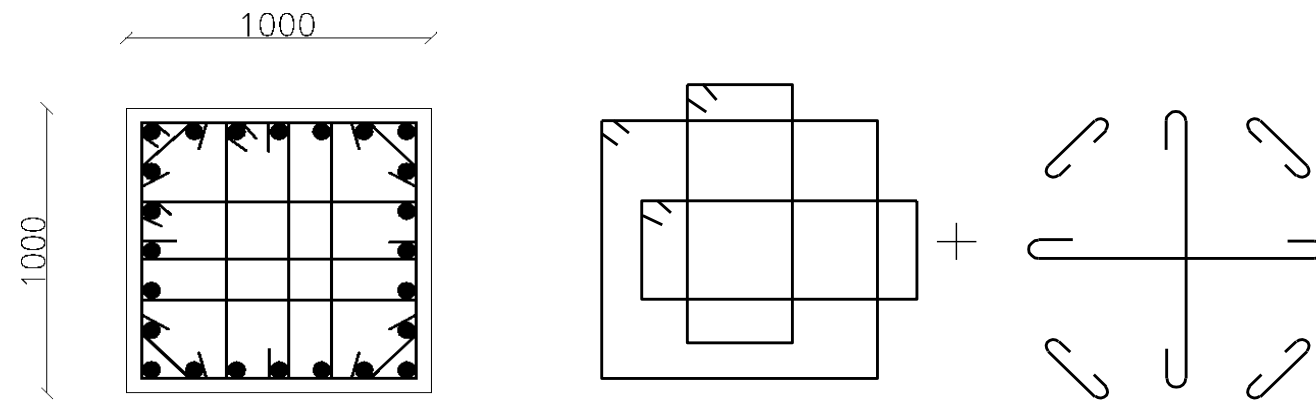

● 24-T12
 T8-150 C/C RINGS
 (3-SET + 6-LINKS)

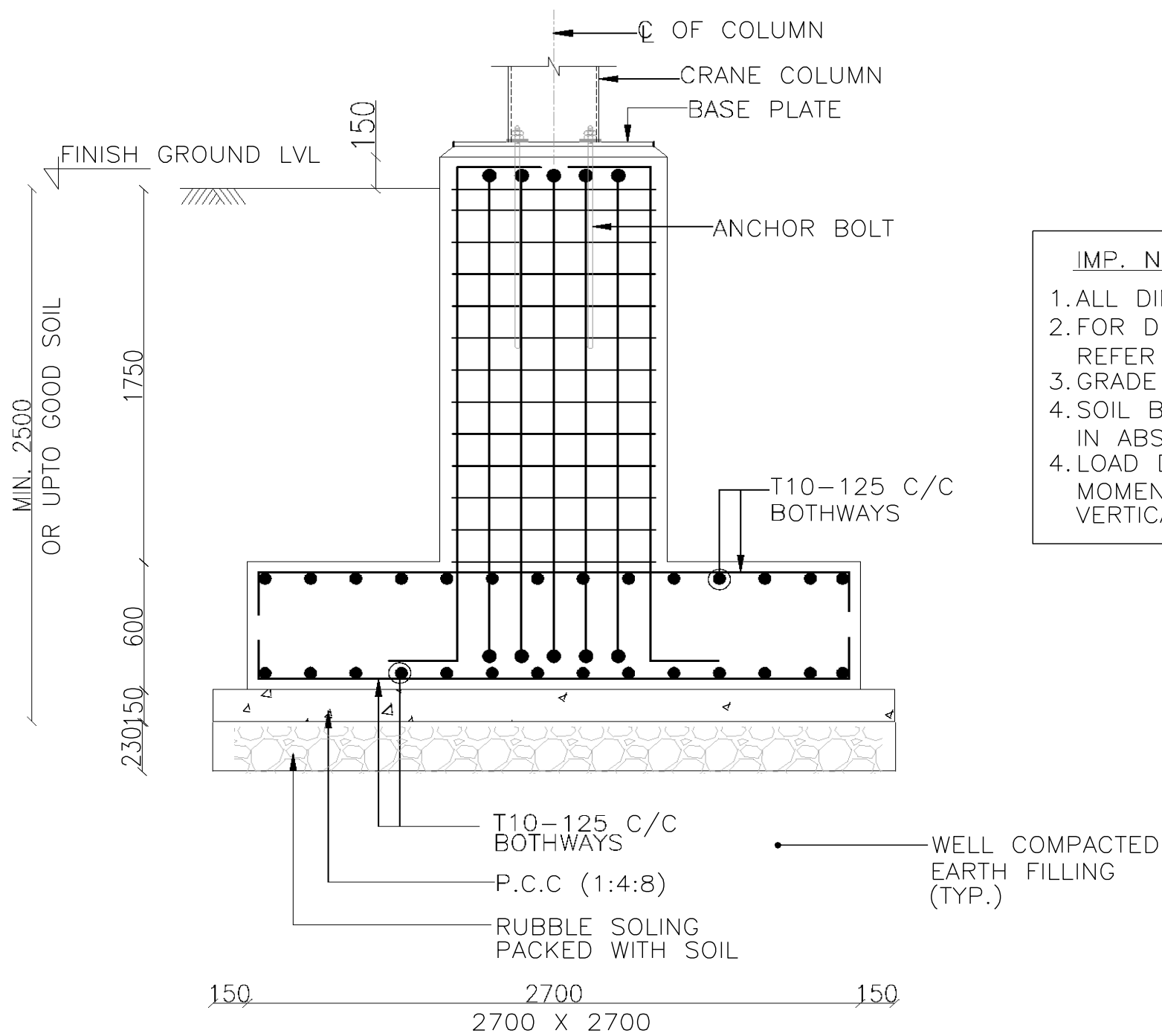

IMP. NOTES

1. ALL DIMENSIONS ARE IN MM.
2. FOR DETAILS OF ANCHOR BOLTS & BASE PLATE REFER CRANE SUPPLIER'S DETAIL.
3. GRADE OF CONCRETE M25 & GRADE OF STEEL FY-500
4. SOIL BEARING CAPACITY CONSIDERED 10 T/SQ.M IN ABSENCE OF SOIL REPORT.
4. LOAD DATA PROVIDED BY SUPPLIER IS;
 MOMENT = 14.0 T.M
 VERTICAL LOAD = 4.0 T

FINANCIAL BID
FOUNDATION WORK FOR
FABRIC ROLL LOADING HOIST CRAIN(Material & Labour Charges)

Sr. No.	Item no.	Description	Quantity	Unit	Rate	Total Amount
1		Excavation for foundation up to 1.5 mt. depth including sorting out and stacking of useful materials and disposing off excavated stuff up to 50 meter lead	16.5	Cum		
2		Excavation for foundation upon 1.5 mt to 3.0 mt depth including sorting out and stacking of useful materials and disposing off excavated stuff up to 50 meter lead	16.5	Cum		
3		Filling available excavated earth in trenchies,sides of foundation .etc in layers not exceeding 20 cm in depth consolidating each deposited layer by ramming and watering	20.5	Cum		
4		Providing & laying cement concrete 1:4:8 (1 cement: 4 coarse sand : 8 hand broken stone aggregates 40 mm nominal size) and curing complete excluding cost of form work in Foundation and plinth	2	Cum		
5		Providing & laying cement concrete 1:2:4 (1 cement : 2 coarse sand : 4 graded stone aggregates 20 mm nominal size) and curing complete excluding cost of form work and reinforcement for reinforced concrete work in				
5.a		(A) Foundations, footings, base of columns, and mass concrete. 11.50 Cum 6500.00 74,750.00 5 Providing & laying cement concrete 1:2:4 (1 cement : 2 coarse sand : 4 graded stone aggregates 20 mm nominal size) and curing complete excluding cost of form work and reinforcement for reinforced concrete work in	11.5			
5.b		(B) Columns, pillars, posts, and struts, up to floor two level	1.5	Cum		
6		Providing, fixing, erecting or lowering in position HYSD of TMT Fe 415 grade conforming to IS 1786 reinforcement of all categories for reinforced cement concrete works in foundations at all levels including cutting, bending, hooks etc. assembling with 18-gauge mild steel binding wires, welding supporting in position to ensure lines and levels during concreting, maintaining proper cover / spacing etc. complete as per specification.	768	Cum		

Scope of work		Design and supply including material, Certified by Civil Authorize persons
Note	1	All work shall be carried out as per public work department hand book and other specifications of Division or as directed
	2	Rates quoted include clearance of site (Prior commencement of work and its close) in all respects and hold good for work under all condition, site, moisture/ weather etc.
	3	The Contractor shall exhibit a board as per Government Circular No. BDG/ 3277/ 1657/ N Dated 26/1/1997 S (M.GUJ) with detailed specification and details of work and amount involved at site without any payment as directed by the Engineer-in-charge.
	4	All the columns in the schedule "B" should be filled in ink and the total in entire in the last columns should be struck by the contractor
	5	Testing of materials shall be as per statement attached with the specification. The material shall be tested in GERI. bill for the testing charge shall be paid by the department.
	6	In R.C.C. item where there is change of grade mix or change as per actual mix design the difference of cement consumption shall be added / deducted from rate of original item at the rate of star rate mentioned in tender

Yours faithfully,

General Manager